

RARE RANGE

3-Ways

Ref : 94021-E-XXX

USER MANUAL



WWW.BOS-SUSPENSION.COM
DRIVEN BY PERFORMANCE



You have just purchased a product from BOS Suspension.
Welcome to our big family!

We have a common passion, motor sports, and this has led us to design neat and high quality products designed for you.

With 20 years of experience in the research, development and production of innovative and efficient products, BOS products are the result of meticulous work and unique know-how. Our entire Toulouse team is proud to accompany you on this great adventure by providing you with the best of our technology, titled in multiple disciplines.

In order to get the most out of your suspensions, we invite you to carefully read the user manual, the assembly instructions and the advice for use in order to make the most of the potential of your new material.

Thank you for choosing BOS Suspension,
Have a good run,

SUMMARY

WARRANTY	3
SAFETY INSTRUCTIONS	4
TOOLS	4
DAMPERS ASSEMBLY	5
REMOVAL OF THE SPRING	6
HYDRAULIC SETTINGS	7
SERVICES	11

WARRANTY

BOS SUSPENSION grants a contractual guarantee under the following conditions:

BOS guarantees its products against all defects in form and manufacturing faults for a period of one year from the date of original purchase. Proof of purchase will be required for any application of the guarantee. The warranty is granted to the original owner and is non-transferable. Wearing parts such as wiper seals, O-rings, guide rings, pins, bushings, screws and bolts are not covered by the warranty.

Application

The application of the warranty is subject to the laws in force in the country or state in which the original owner resides. If the local legislation differs from the warranty as described here, the warranty is deemed to be amendable to comply with it.

Limits

BOS SUSPENSION is not liable for direct, indirect, special, incidental or unforeseen damage resulting from the use of its products, subject to compliance with local legislation.

Exclusion

The guarantee does not apply in the following cases :

- Failure to comply with the installation instructions as described in the installation and adjustment manual.
- Failure to follow the disassembly/assembly instructions as described in the service manual.
- Modifications made to the product by the owner or a third party.
- Inappropriate use.
- Damage resulting from an accident, violent shock,

- Replacement of original parts with parts from manufacturers other than BOS SUSPENSION.
- Alteration of the serial numbers with the obvious aim of making it illegible.

Procedure

Regardless of where the product was purchased, the owner must contact an authorised BOS centre to apply for the guarantee. It is compulsory to produce the purchase invoice. Otherwise, the warranty will not apply. Sending the product is subject to the prior agreement of the BOS SUSPENSION after-sales service department. Outward carriage, dismantling and packaging costs are the responsibility of the customer. In the event of refusal to apply the guarantee, the packaging and return shipping costs are the responsibility of the customer.

SAFETY INSTRUCTIONS

GENERAL WARNINGS

Your suspension is an important component that has a direct influence on the handling of your vehicle.

This manual must be consulted before using the BOS suspension and during its entire service life.

If necessary, or for any service work, please contact an authorised BOS Suspension Centre.



After installation, test your vehicle at low speed to ensure that the system is working properly.

 **CAUTION** operations may impair your safety or cause damage to your suspension. Be sure to take note of these warnings.

 **IMPORTANT INFORMATIONS**
These indications are intended to allow you to optimize the operations described in this manual or optimize the performance of your suspension. Do not attempt to disassemble your shock absorber; limit yourself to the operations described in this manual. Since your shock absorber is assembled under pressure, disassembling it may cause injury. Disassembling your shock absorber may cause irreversible damage to it. Contact an authorized BOS service center for maintenance.

TOOLS

To carry out adjustments and routine maintenance of your suspension kit, you will need the following tools :

TOOLS	USE	FIGURE
5 and 6mm pin spanner	Spring preload	-
4mm Allen key	Rebound damping	
Flat screwdriver	Low speed bump	
14mm Socket	High speed bump	



DAMPERS ASSEMBLY



- We strongly recommend to let a professional install this product
- Wash the vehicle before installing this product

1. Put the vehicle on a stand
2. Remove the wheel
3. Disconnect all components attached to the shock absorber (anti-roll bar, sensors, etc)
4. Loosen the upper and lower mounting screw before removing the original shock absorber from the vehicle
5. Install the BOS shock absorber in place of the original one. Then tighten the upper and lower mounting screws
6. Repeat the operation on all 4 wheels of the vehicle

The vehicle is ready to be placed on its wheels

7. Once the vehicle is on the ground, you can adjust the ride height of the vehicle to your wishes by preloading or unloading your spring (variation of the x value). To do this, you can use a pin wrench or two pin drivers for example. Remember to note and keep this value

If you loosen the preload nut, you decrease the ride height of the car and vice versa if you tighten it. This adjustment is not considered as a tuning way. It is an adjustment that depends mainly on the use and the feeling of the driver.

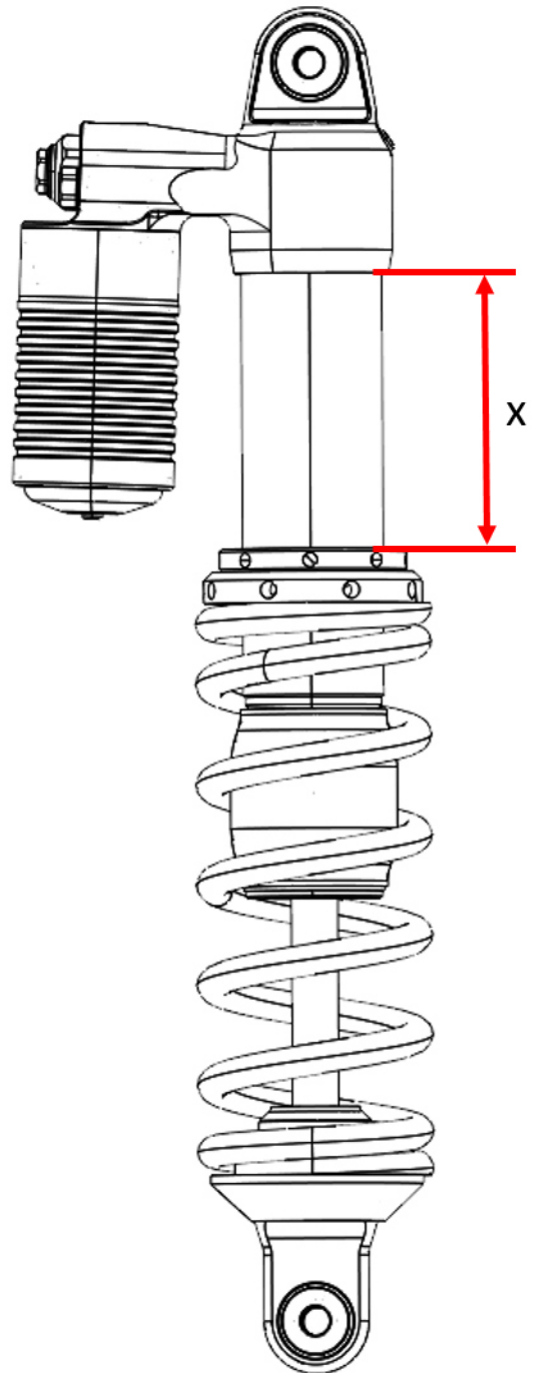

REMOVAL OF THE SPRING

1. Remove the shock absorber from the vehicle
2. Loosen the preload nut/locknut until the spring is free
3. Slide the spring up (1)
4. Slide the bump stop up around the rod
5. Remove the cup from the foot of the shock absorber (2)
6. Slide the main spring from the bottom of the damper (3)
7. Reassemble the spring in the reverse order

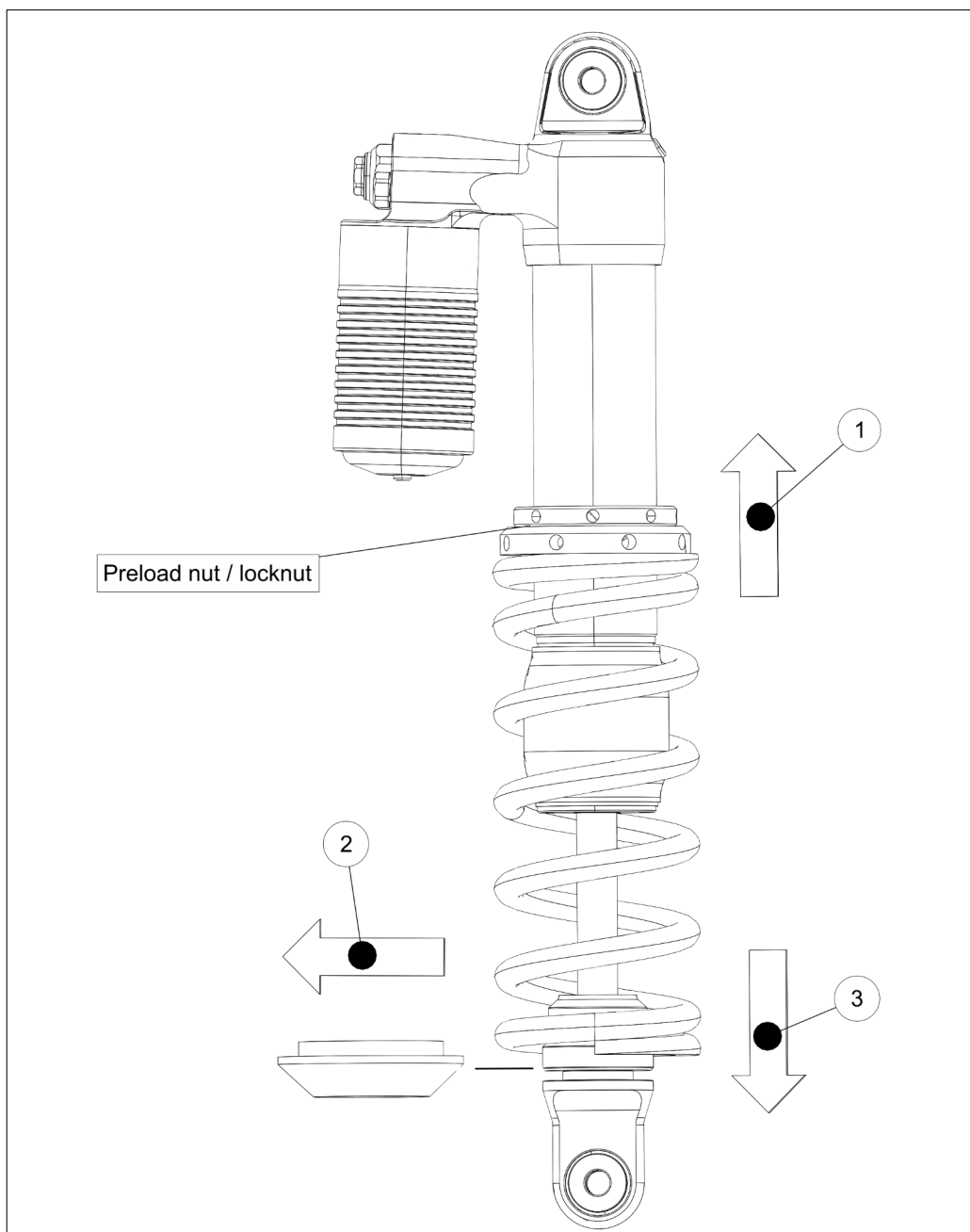

HYDRAULIC SETTINGS

The shock absorber is of the "3-ways" type, which means that it has three main hydraulic adjustment channels affecting the hydraulic curve of the shock absorber: rebound, low speed compression and high speed compression. The basic setting (internal hydraulics) of your shock absorber corresponds to the kinematics and weights of your vehicle.

The objective of the hydraulic settings is to use the whole stroke of the shock absorber, without bottoming out or very rarely, to give grip to the wheel, but also to avoid blocking in the holes, and finally to keep a correct pitch. We show you here the basic step for your chassis settings. It's up to you to analyze its tendencies and adjust the settings according to your riding style. Proceed carefully, step by step, with method. Change only one setting at a time by varying only a few clicks. Once validated, make a note of your setting, according to the type of track. If you are lost in the settings, go back to the basic settings, and start again.



Adjustments are always made from the fully closed position and then by unscrewing. Once you have reached the closed position, you must not continue to screw otherwise you risk to damage your shock absorber

Low speed compression (A) LSC

The low speed compression allows to act on the behavior of the shock absorber in compression on small shocks, or the first few millimeters of stroke. You can then manage the chassis movements of your vehicle. It can be useful to harden (screw) the low speed, when the track is rolling, with strong downforce.

It can be useful to soften the low speed (loosen) in more complicated conditions.

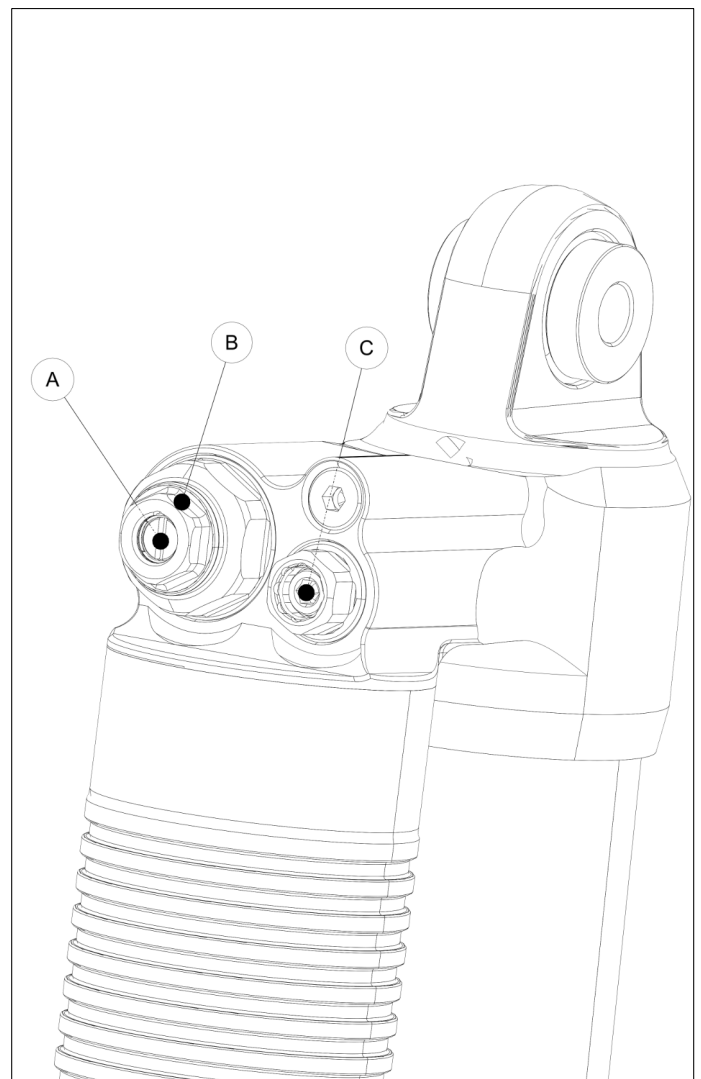

HYDRAULIC SETTINGS

High Speed Compression (B) HSC

The high speed compression acts essentially on violent shocks (jump landings, broken sections). It should be soft enough to use the full stroke of the shock without bottoming out.

If you heel a lot on a given track, harden (screw) the HSC compression. However, don't focus on eliminating heeling if it only happens once or twice on a given track. You may be setting your damper for only 3% of the track and losing effectiveness on the other 97%.

If your shock is not using all of the travel, loosen the HV compression.

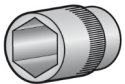

REBOUND (C)

The most important criteria for adjusting the rebound is the pitch and grip of your vehicle. This adjustment will allow you to keep the right dynamic ride height and to maximize the grip by keeping the wheels on the track. Also, the harder the rebound will be (screw), the lower the dynamic attitude will be and vice versa. The result is a gain in precision, comfort, traction and better roll management.



HYDRAULIC SETTINGS

Some « typical » solutions :

Before discussing these adaptive solutions, it should be noted that the standard settings provided by BOS for your shocks are a reliable starting point, which should be suitable for most drivers under normal operating conditions. However, depending on the track conditions, your driving style and your vehicle, you may have to adjust your shock absorbers differently. If this is the case, you can follow the following adjustment guidelines to avoid getting lost in the tuning process.

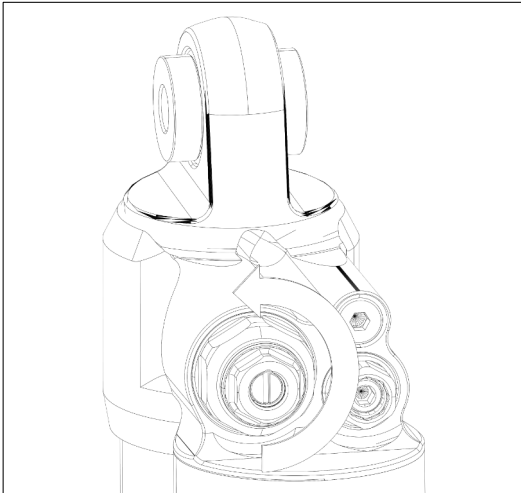

(+) Opening of the clicks (unscrewing), softening of the adjustment way

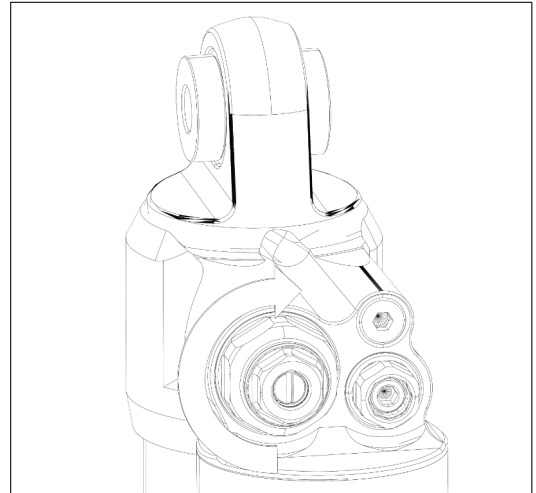

(-) Closing of the clicks (screwing), hardening the adjustment way

Bottoming in					
HS Compression		LS Compression		Rebound	
Front	Rear	Front	Rear	Front	Rear
-4 clicks	-4 clicks	-2 clicks	-2 clicks	0	0

Pumping / Dribbling					
HS Compression		LS Compression		Rebound	
Front	Rear	Front	Rear	Front	Rear
-3 clicks	-3 clicks	-2 clicks	-2 clicks	-2 clicks	-2 clicks

Unstable car in accelerator/brake transition					
HS Compression		LS Compression		Rebound	
Front	Rear	Front	Rear	Front	Rear
0	0	0	0	0	-4 clicks

HYDRAULIC SETTINGS

Lack of longitudinal motricity

HS Compression		LS Compression		Rebound	
Front	Rear	Front	Rear	Front	Rear
0	0	+3 clicks	+3 clicks	+2 clicks	+2 clicks

Understeer on corner entry

HS Compression		LS Compression		Rebound	
Front	Rear	Front	Rear	Front	Rear
0	0	+2 clicks	0	0	0

Understeer on corner exit

HS Compression		LS Compression		Rebound	
Front	Rear	Front	Rear	Front	Rear
0	0	0	-2 clicks	0	0

Oversteer on corner entry

HS Compression		LS Compression		Rebound	
Front	Rear	Front	Rear	Front	Rear
0	0	-2 clicks	0	0	-2 clicks



Please note that these solutions are general guidelines but may not be suitable for your vehicle, your driving style or your driving conditions. You are free to explore your own settings.

Maintenance

It is essential to clean your shock absorber after each run, and without delay! Nothing is more dangerous for the seals than dried mud. However, the operation is very simple: just clean the rod and the seals with a soft cloth, then grease it lightly with silicone.



Do not use any aggressive products such as degreasers. If you use a high-pressure washer, never direct the jet directly on the seals. Make sure to regularly remove any dirt that may accumulate in the rubber stop.

		After each ride	Each 6 months	Each year	Each 2 years
Cleaning		x			
Light service	Wet / Muddy conditions		x		
	Races / frequent use		x		
	Dry / Dusty conditions			x	
Complete service	Wet / Muddy conditions			x	
	Races / frequent use			x	
	Dry / Dusty conditions				x
Inspection of guide bushing	Wet / Muddy conditions		x		
	Races / frequent use		x		
	Dry / Dusty conditions				x



The oil change and overhaul must be carried out by an authorized BOS center, which is also the only one capable of identifying and assessing damaged or worn components, especially in the event of impact or premature wear of structural components such as the rod, balls joint and pistons.



Never attempt to change the pressure in the damper canister. This is not an adjustment, the gas is only used to pressurize the hydraulic fluid to prevent cavitation. Attempting to change the cylinder pressure will only cause your damper to fail.

SERVICES

For any specific intervention and (or) request for parts we invite you to visit our website **WWW.BOS-SUSPENSION.COM** or contact us at the following email address **sales@bos-suspension.com**. Our teams of experts are at your disposal to answer your questions and to carry out the maintenance operations of your shock absorbers.

USER MANUAL



WWW.BOS-SUSPENSION.COM
DRIVEN BY PERFORMANCE